

RE 29 055/08.01

Replaces: 06.00

**4/2- and 4/3-way proportional directional
valves, direct actuated,
without electrical position feedback
Types 4WRA and 4WRAE**

Nominal sizes 6 and 10

Series 2X

Maximum operating pressure 315 bar

Maximum flow 42 L/min (NS 6)

Maximum flow 75 L/min (NS 10)

Overview of contents

Description	Page
Features	1
Ordering details	2
Preferred types	3
Symbols	3
Function, section	4
Technical data	5 to 6
Electrical connections, plug-in connectors	7
Integrated valve electronics for type 4WRAE	8
Characteristic curves	9 to 11
Unit dimensions	12 to 15

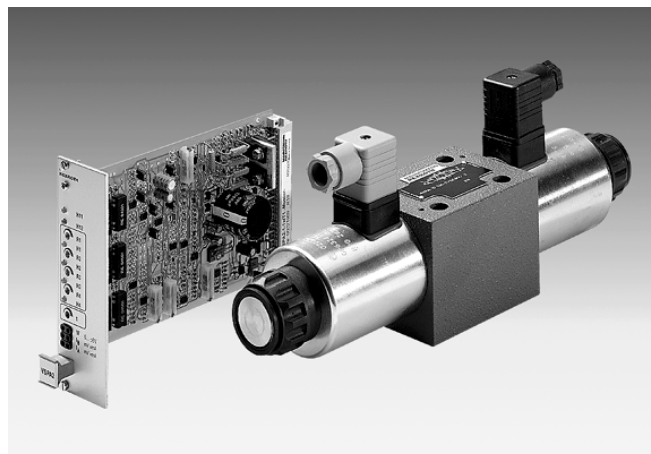

H/A/D 5964/98

Type 4WRA 10 ...-2X/G24...K4/V with plug-in connectors and associated control electronics (separate order)

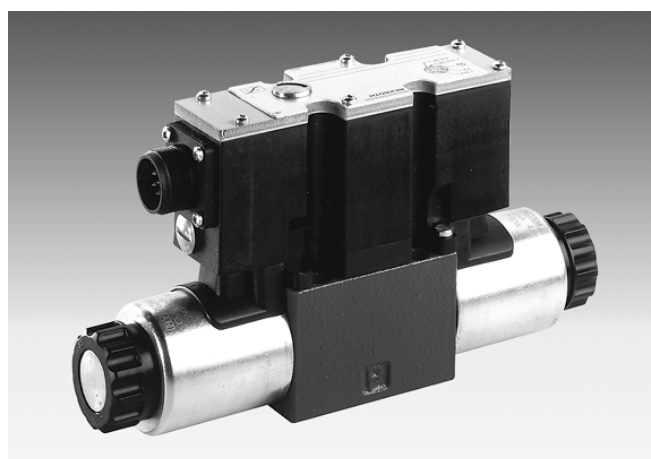

H/A 4678/95

Type 4WRAE 6 ...-2X/G24K31/V

Features

- Direct actuated proportional valve for controlling the direction and volume of a flow
- Actuation by means of proportional solenoids with central thread and removable coil
- For subplate mounting: Porting pattern to DIN 24 340 form A, ISO 4401 and CETOP-RP 121 H.
Subplates to catalogue sheets RE 45 052 (NS 6) or RE 45 054 (NS 10) separate order, see pages 12 to 15
- Spring centred control spool
- Integrated control electronics, interface A1 or F1 for type 4WRAE
- Control electronics for type WRA:
 - Electrical amplifier VT-VSPA2-1-1X in Eurocard format (separate order), see RE 30 112
 - Digital amplifier VT-VSPD-1-1X in Eurocard format (separate order), see RE 30 123



© 2002
by Bosch Rexroth AG, Industrial Hydraulics, D-97813 Lohr am Main

All rights reserved. No part of this document may be reproduced or stored, processed, duplicated or circulated using electronic systems, in any form or by any means, without the prior written authorisation of Bosch Rexroth AG. In the event of contravention of the above provisions, the contravening party is obliged to pay compensation.

This document was prepared with the greatest of care, and all statements have been examined for correctness. This document is subject to alterations for reason of the continuing further development of products. No liability can be accepted for any incorrect or incomplete statements.

Ordering details

4WRA				- 2X / G24		/	V	*
------	--	--	--	------------	--	---	---	---

Without integrated control electronics = No code
With integrated control electronics = E

Nominal size 6 = 6
 Nominal size 10 = 10

Symbols

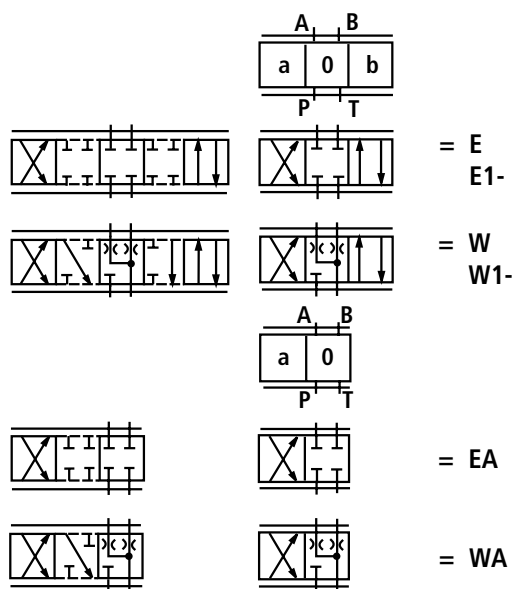

With symbols E1- and W1-:
 P → A: $q_{V \max}$ B → T: $q_V/2$
 P → B: $q_V/2$ A → T: $q_{V \max}$

Note:
 With spools W and WA in the neutral position there is a connection from A to T and B to T with approx. 3 % of the relevant nominal cross-section.

Further details in clear text
 V = FKM seals, suitable for mineral oil (HL, HLP) to DIN 51 524

No code = For WRA
 For WRAE:
 A1 = Command value input ± 10 V
 F1 = Command value input 4 to 20 mA

Electrical connections

For WRA:
²⁾ K4 = Without plug-in connector, with component plug to DIN EN 175 301-803
 Plug-in connector – separate order see page 7
 For WRAE:
²⁾ K31 = Without plug-in connector, with component plug to E DIN 43 563-AM6-3
 Plug-in connector – separate order see page 7

Special protection

No code = Without special protection
¹⁾ J = Sea water resistant (only for NS 6)
 For details regarding the sea water resistance see RE 29 055-M

G24 = Supply voltage 24 VDC

2X = Series 20 to 29
 (20 to 29: unchanged installation and connection dimensions)

Nominal flow at a valve pressure differential $\Delta p = 10$ bar

	NS 6
07 =	7 L/min
15 =	15 L/min
30 =	26 L/min
	NS 10
30 =	30 L/min
60 =	60 L/min

¹⁾ Other types of electrical protection on request
²⁾ Only for NS 6: for version "J" = sea water resistant only state "K31"!

Preferred types

NS 6

Material no.	Type
00910780	4WRA 6 E07-2X/G24K4/V
00904438	4WRA 6 E15-2X/G24K4/V
00904439	4WRA 6 E30-2X/G24K4/V
00954053	4WRA 6 E1-15-2X/G24K4/V
00947835	4WRA 6 E1-30-2X/G24K4/V
00954054	4WRA 6 EA15-2X/G24K4/V
00954055	4WRA 6 EA30-2X/G24K4/V
00928412	4WRA 6 W07-2X/G24K4/V
00954056	4WRA 6 W15-2X/G24K4/V
00954407	4WRA 6 W30-2X/G24K4/V
00954057	4WRA 6 W1-15-2X/G24K4/V
00954058	4WRA 6 W1-30-2X/G24K4/V
00954059	4WRA 6 WA15-2X/G24K4/V
00935535	4WRA 6 WA30-2X/G24K4/V
00954069	4WRAE 6 E07-2X/G24K31/A1V
00954070	4WRAE 6 E15-2X/G24K31/A1V
00954071	4WRAE 6 E30-2X/G24K31/A1V
00954072	4WRAE 6 E1-15-2X/G24K31/A1V
00954073	4WRAE 6 E1-30-2X/G24K31/A1V
00954074	4WRAE 6 EA15-2X/G24K31/A1V
00954075	4WRAE 6 EA30-2X/G24K31/A1V
00954076	4WRAE 6 W07-2X/G24K31/A1V
00954077	4WRAE 6 W15-2X/G24K31/A1V
00954078	4WRAE 6 W30-2X/G24K31/A1V
00954079	4WRAE 6 W1-15-2X/G24K31/A1V
00954080	4WRAE 6 W1-30-2X/G24K31/A1V
00954081	4WRAE 6 WA15-2X/G24K31/A1V
00954082	4WRAE 6 WA30-2X/G24K31/A1V

NS 10

Material no.	Type
00954060	4WRA 10 E30-2X/G24K4/V
00954061	4WRA 10 E60-2X/G24K4/V
00954062	4WRA 10 E1-30-2X/G24K4/V
00954063	4WRA 10 E1-60-2X/G24K4/V
00954408	4WRA 10 EA30-2X/G24K4/V
00954064	4WRA 10 EA60-2X/G24K4/V
00577424	4WRA 10 W30-2X/G24K4/V
00954065	4WRA 10 W60-2X/G24K4/V
00954066	4WRA 10 W1-30-2X/G24K4/V
00954067	4WRA 10 W1-60-2X/G24K4/V
00954068	4WRA 10 WA30-2X/G24K4/V
00952054	4WRA 10 WA60-2X/G24K4/V
00933793	4WRAE 10 E30-2X/G24K31/A1V
00954083	4WRAE 10 E60-2X/G24K31/A1V
00954084	4WRAE 10 E1-30-2X/G24K31/A1V
00954409	4WRAE 10 E1-60-2X/G24K31/A1V
00954085	4WRAE 10 EA30-2X/G24K31/A1V
00954086	4WRAE 10 EA60-2X/G24K31/A1V
00954087	4WRAE 10 W30-2X/G24K31/A1V
00954088	4WRAE 10 W60-2X/G24K31/A1V
00953496	4WRAE 10 W1-30-2X/G24K31/A1V
00954089	4WRAE 10 W1-60-2X/G24K31/A1V
00954090	4WRAE 10 WA30-2X/G24K31/A1V
00954091	4WRAE 10 WA60-2X/G24K31/A1V

Symbols

Proportional directional valve without integrated control electronics

Type WRA...

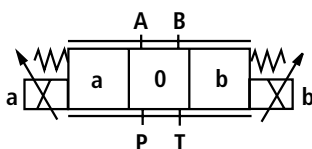

Type WRA...A...

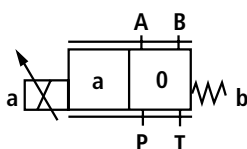

Proportional directional valve with integrated control electronics

Type WRAE...

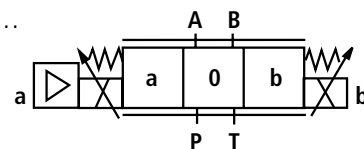

Type WRAE...A...

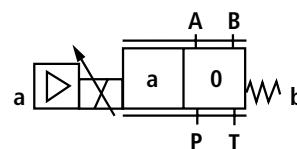

Function, section

The 4/2- and 4/3-way proportional directional valves are designed as direct operated components for subplate mounting. They are actuated by means of proportional solenoids with central thread and removable coil. The solenoids are controlled either by external control electronics (type WRA) or by integrated control electronics (type WRAE).

Design:

The valves basically consist of:

- Housing (1) with mounting surface
- Control spool (2) with compression springs (3 and 4)
- Solenoids (5 and 6) with central thread
- Optional integrated valve electronics (7)

Functional description:

- With the solenoids (5 and 6) de-energised, the control spool (2) is held in the central position by compression springs (3 and 4)
- Direct actuation of the control spool (2) by energising a proportional solenoid
E.g. controlling of solenoid "b" (6)
→ The control spool (2) is moved to the left in proportion to the electrical input signal
→ Connection from P to A and B to T via orifice-like cross sections with progressive flow characteristics
- De-energisation of the solenoid (6)
→ The control spool (2) is returned to the central position by compression spring (3)

Type 4WRA 6...-2X/...

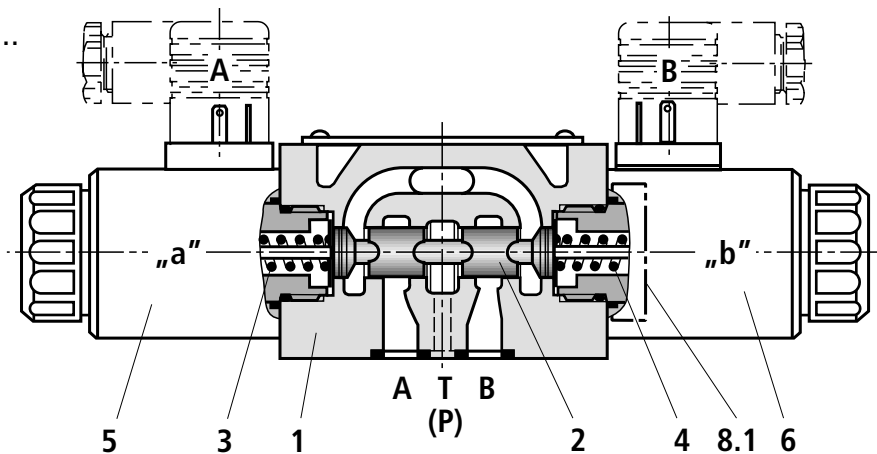

Type 4WRAE 10...-2X/...

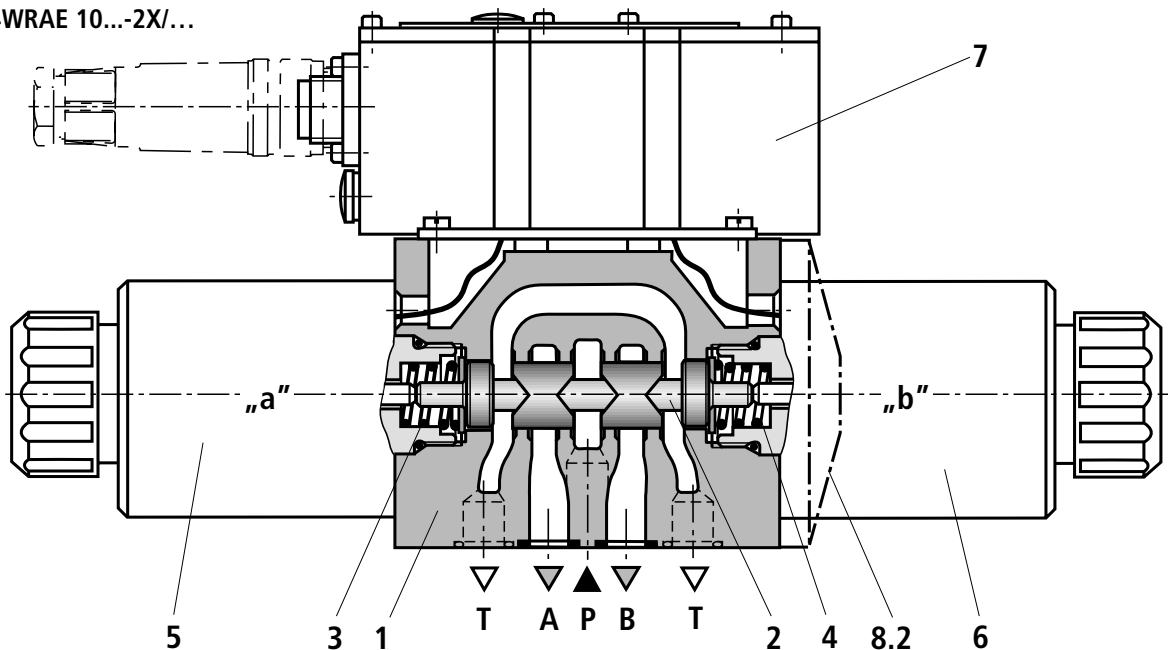

Valve with 2 spool positions:

(Type 4WRA...A...)

In principle, the function of this valve version corresponds to that of the valve with 3 spool positions. However, the valves with 2 spool positions are only fitted with solenoid "a". Instead of the 2nd proportional solenoid a plug (8.1) is fitted for NS 6 or for NS 10 a cover (8.2).

Note for type 4WRA 6...-2X/...:

Draining of the tank line is to be avoided. With the appropriate installation conditions, a back pressure valve is to be installed (back pressure approx 2 bar).

Technical data (for applications outside these parameters, please consult us!)

General

Valve type			WRA	WRAE
Installation		optional, preferably horizontal		
Storage temperature range		°C	– 20 to + 80	
Ambient temperature range		°C	– 20 to + 70	– 20 to + 50
Weight	NS 6	kg	2.0	2.2
	NS 10	kg	6.6	6.8

Hydraulic (measured at $p = 100$ bar, with HLP46 at $40\text{ °C} \pm 5\text{ °C}$)

Operating pressure	Ports A, B, P	bar	up to 315	
	Port T	bar	up to 210	
Nominal flow $q_{V, \text{nom}}$ at $\Delta p = 10$ bar	NS 6	L/min	7, 15 and 26	
	NS 10	L/min	30 and 60	
Max. permissible flow	NS 6	L/min	42 (80 with double flow)	
	NS 10	L/min	75 (140 with double flow)	
Pressure fluid		Mineral oil (HL, HLP) to DIN 51 524 other pressure fluids on request!		
Pressure fluid temperature range		°C	– 20 to + 80 (preferably + 40 to + 50)	
Viscosity range		mm ² /s	20 to 380 (preferably 30 to 46)	
Degree of contamination		Maximum permissible degree of contamination of the pressure fluid is to NAS 1638		Filter with a minimum retention rate of $\beta_x \geq 75$ is recommended
		class 9		x = 10
Hysteresis		%	≤ 5	
Reversal error		%	≤ 1	
Response sensitivity		%	≤ 0.5	

Technical data (for applications outside these parameters, please consult us!)

Electrical

Valve type			WRA ¹⁾	WRAE
Voltage type			DC	
Command value signal	Voltage input „A1“	V	± 10	± 10
with type WRAE	Current input „F1“	mA	4 to 20	4 to 20
Max. current per solenoid		A	2.5	2.5
Solenoid coil resistance	Cold value 20 °C	Ω	2	2
	Max. warm value	Ω	3	3
Duty		%	100	
Max. coil temperature ²⁾		°C	Up to 150	
Electrical connections see page 7	WRA	With component plug to DIN EN 175 301-803 and ISO 4400		
		Plug-in connector to DIN EN 175 301-803 and ISO 4400 ³⁾		
	WRAE	With component plug to E DIN 43 563-AM6-3		
		Plug-in connector E DIN 43 563-BF6-3/Pg11 ³⁾		
Valve protection to DIN 40 050		IP 65 with fitted and locked plug-in connector		

Control electronics

For WRA	Amplifier in Eurocard format ³⁾		VT-VSPA2-1-1X/... see RE 30 112	
	Digital amplifier in Eurocard format ³⁾		VT-VSPD-1-1X see RE 30 123	
For WRAE	Integrated into the valves, see page 8			
	Analogue command value module		VT-SWMA-1-1X/... see RE 29 902	
	Analogue command value module		VT-SWMKA-1-1X/... see RE 29 903	
	Analogue command value module		VT-SWKA-1-1X/... see RE 30 255	
	Digital command value module		VT-SWKD-1-1X/... see RE 30 121	
Supply voltage	Nominal voltage	VDC	24	
4WRAE, 4WRA ¹⁾	Lower limiting value	V	21 / 22	19
	Upper limiting value	V	35	
Amplifier current consumption	I_{max}	A	1.8	1.8
	Max. impulse current	A	3	3

¹⁾ With Bosch Rexroth AG control electronics

²⁾ Due to the occurring surface temperature of the solenoid coils, the European Standards EN 563 and EN 982 must be taken into account!

³⁾ Separate order



Note: For details regarding the **environmental simulation test** covering EMC (electro-magnetic compatibility), climate and mechanical loading see RE 29 055-U (declaration regarding environmental compatibility).

Electrical connection, plug-in connectors

For type WRA

(without integrated control electronics – **not** for version "J" = sea water resistant)

Connection on component plug

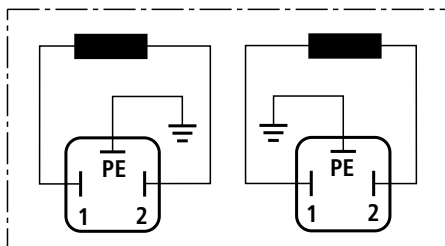

Connection on plug-in connector

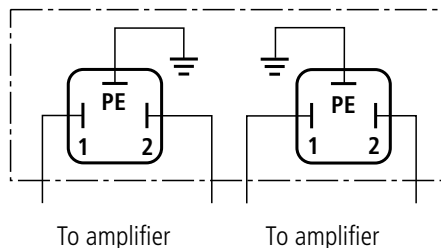

Plug-in connector CECC 75 301-803-A002FA-H3D08-G to DIN EN 175 301-803 and ISO 4400

Solenoid **a**, colour grey

Separate order under material no. **00074683**

Solenoid **b**, colour black

Separate order under material no. **00074684**

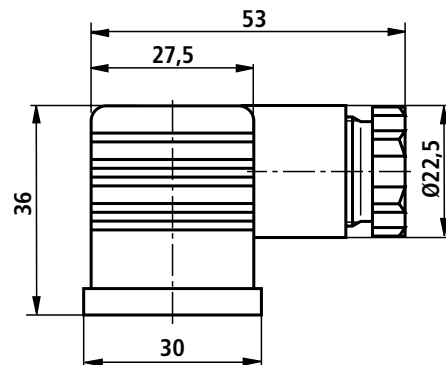
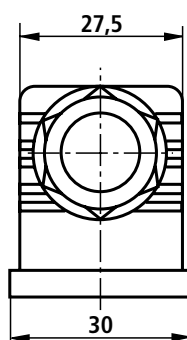

For type WRAE

(with integrated electronics and for version "J" = sea water resistant)

For pin allocation, see block circuit diagram on page 8

Plug-in connector to E DIN 43 563-BF6-3/Pg11

Separate order under material no. **00021267** (plastic version)

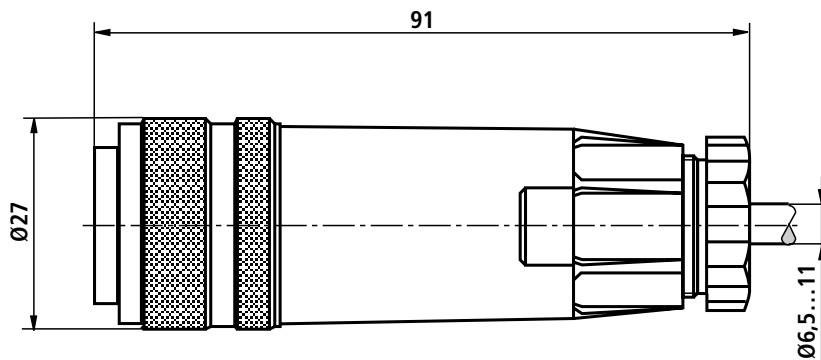

Plug-in connector to E DIN 43 563-BF6-3/Pg13,5

Separate order under material no. **00223890** (metal version)

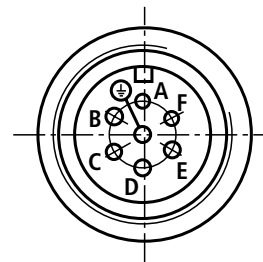
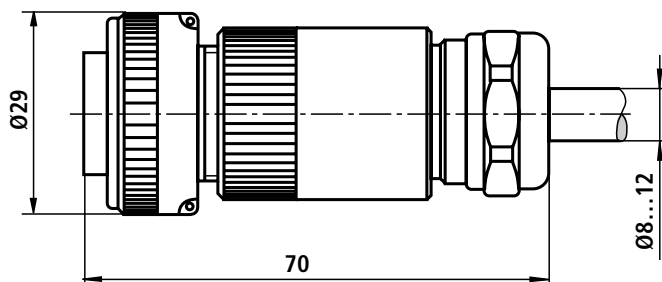

Integrated control electronics for type WRAE

Pin allocation of the component plug

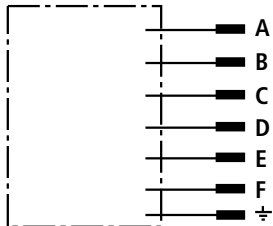

Integrated electronics
(see below)

	Slot	Signal
Supply voltage	A	24 VDC (19 to 35 VDC)
	B	GND
	C	n.c. ¹⁾
Differential amplifier input	D	com. value ($\pm 10\text{ V} / 4\text{ to }20\text{ mA}$)
	E	ref. potential
	F	n.c. ¹⁾

Com. value: Positive command value (0 to 10 V or 12 to 20 mA) at D and reference potential to E causes flow from P to A and B to T. Negative command value (0 to -10 V or 12 to 4 mA) at D and reference potential to E causes flow from P to B and A to T.

For valves with a solenoid on side „a“ (spool variant **EA** and **WA**) reference potential to E and positive command value at D (NS 6: 4 to 20 mA and NS 10: 12 to 20 mA) causes flow from P to B and A to T.

Connection cable: Recommendation: – up to 25 m cable length type LiYCY 5 x 0.75 mm²
– up to 50 m cable length type LiYCY 5 x 1.0 mm²

External diameter 6.5 to 11 mm

Connect screen to PE only on the supply side.

¹⁾ Slots C and F must not be connected!

Block circuit diagram/terminal allocation of the integrated control electronics

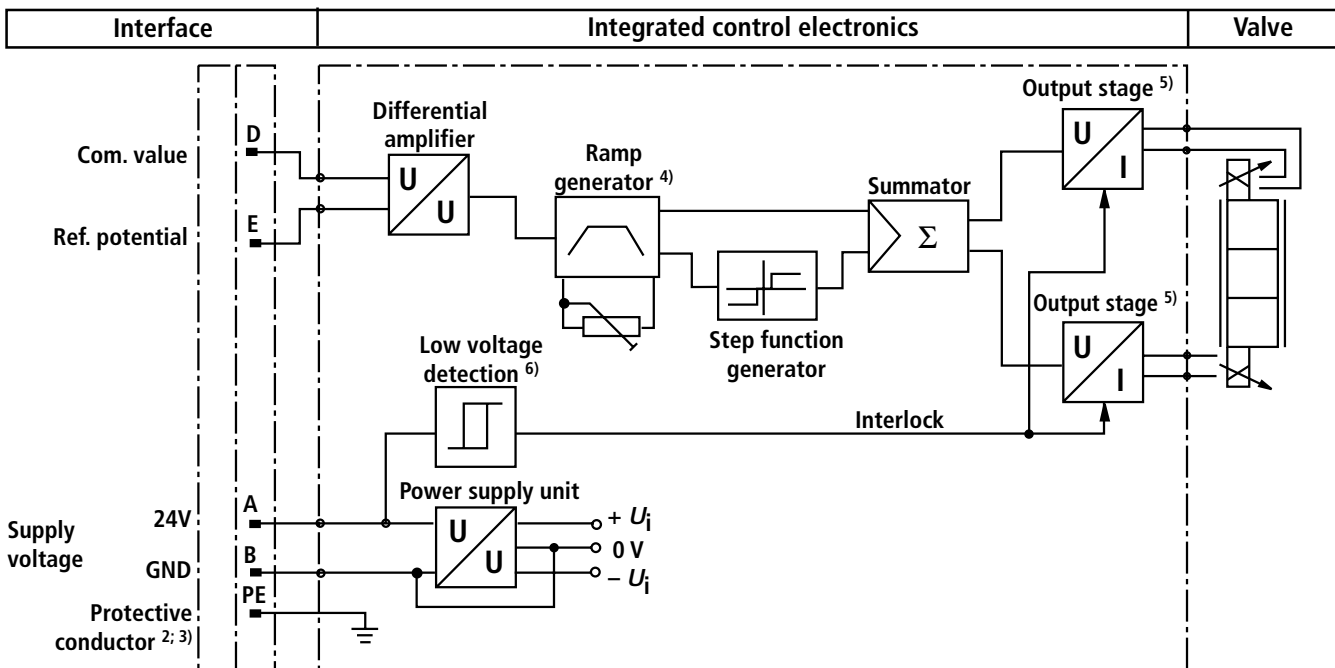

²⁾ PE is connected to the cooling body and the valve housing

³⁾ Protective conductor screwed to the valve housing and cover

⁴⁾ Ramp can be externally adjusted from 0 to 2,5 s; the same applies for T_{up} and T_{down}

⁵⁾ Output stages current regulated

⁶⁾ Low voltage detection is **not** carried out for component type 4WRAE 10-2X.

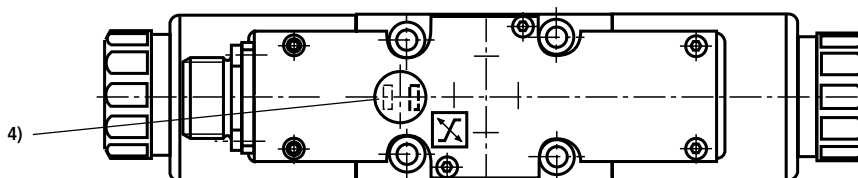

7 L/min nominal flow at 10 bar valve pressure differential

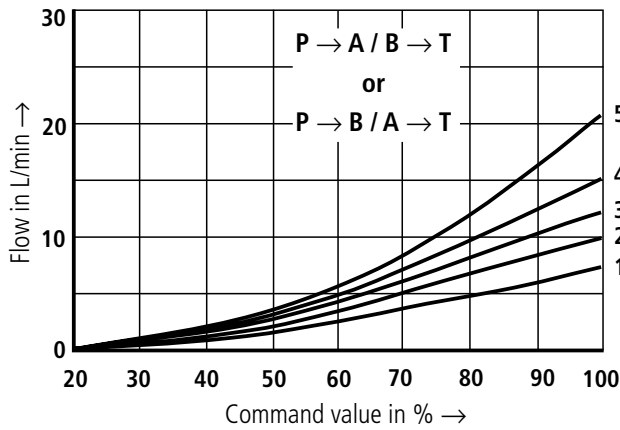

15 L/min nominal flow at 10 bar valve pressure differential

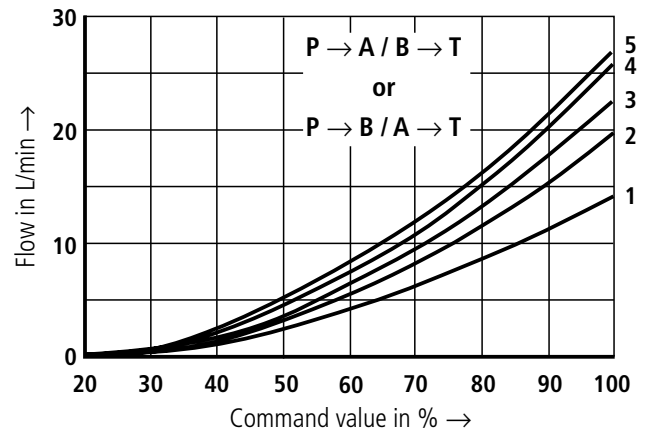

30 L/min nominal flow at 10 bar valve pressure differential

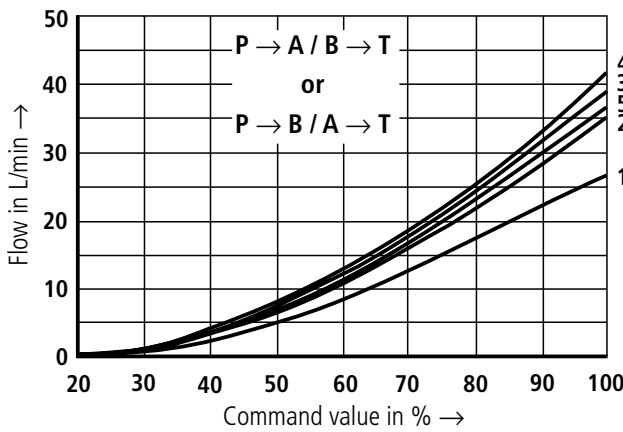

- 1 $\Delta p = 10$ bar constant
- 2 $\Delta p = 20$ bar constant
- 3 $\Delta p = 30$ bar constant
- 4 $\Delta p = 50$ bar constant
- 5 $\Delta p = 100$ bar constant

$\Delta p =$ Valve pressure differential (inlet pressure p_p minus load pressure p_l and minus return pressure p_r)

30 L/min nominal flow at 10 bar valve pressure differential

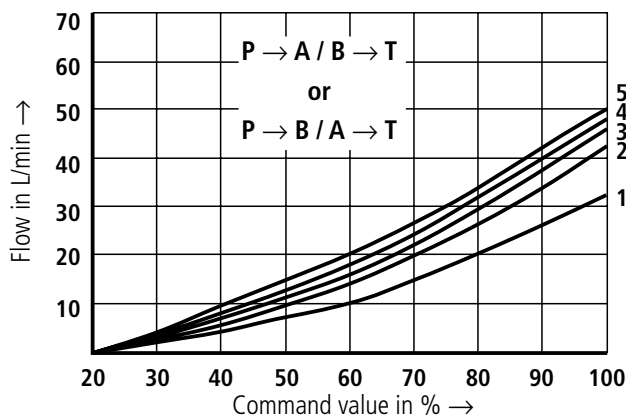

- 1 $\Delta p = 10$ bar constant
- 2 $\Delta p = 20$ bar constant
- 3 $\Delta p = 30$ bar constant
- 4 $\Delta p = 50$ bar constant
- 5 $\Delta p = 100$ bar constant

60 L/min nominal flow at 10 bar valve pressure differential

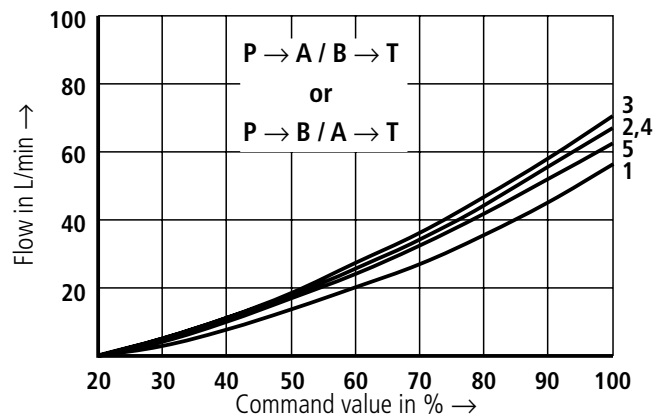

$\Delta p =$ Valve pressure differential (inlet pressure p_p minus load pressure p_l and minus return pressure p_r)

Transient functions with stepped form of electrical input signals

Types WRA and WRAE

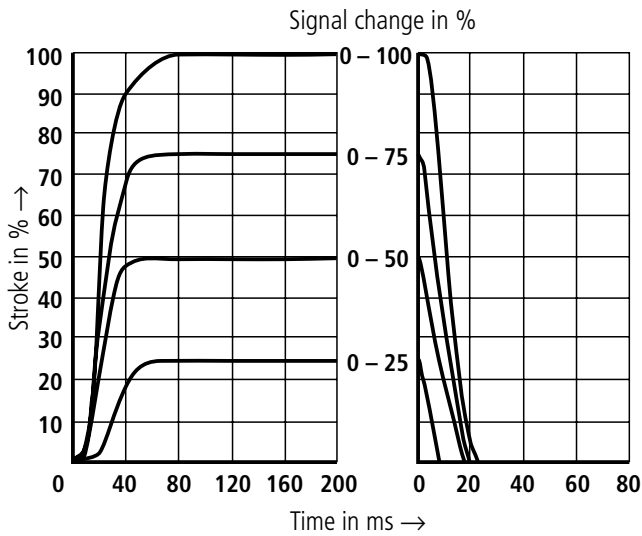

Performance limit, nominal flow 7 L/min

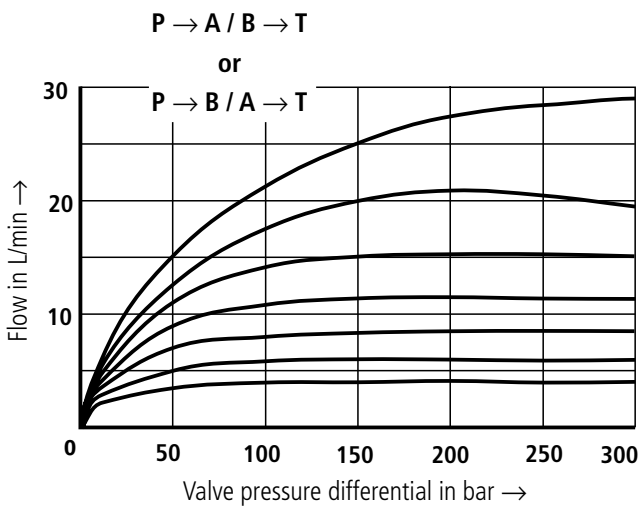

Performance limit, nominal flow 15 L/min

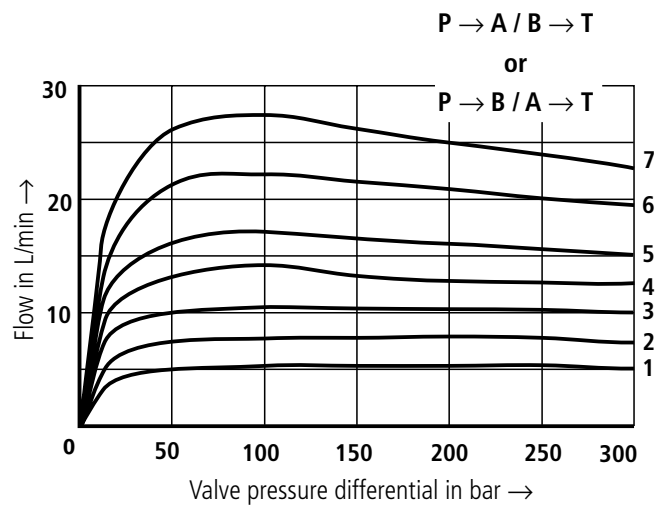

Performance limit, nominal flow 30 L/min

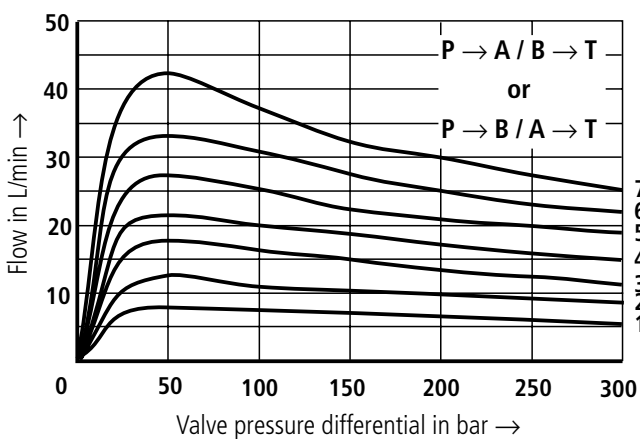

- 1 Command value = 40 %
- 2 Command value = 50 %
- 3 Command value = 60 %
- 4 Command value = 70 %
- 5 Command value = 80 %
- 6 Command value = 90 %
- 7 Command value = 100 %

If the performance limits are exceeded then flow forces occur which lead to uncontrolled spool movements.

Transient functions with stepped form of electrical input signals

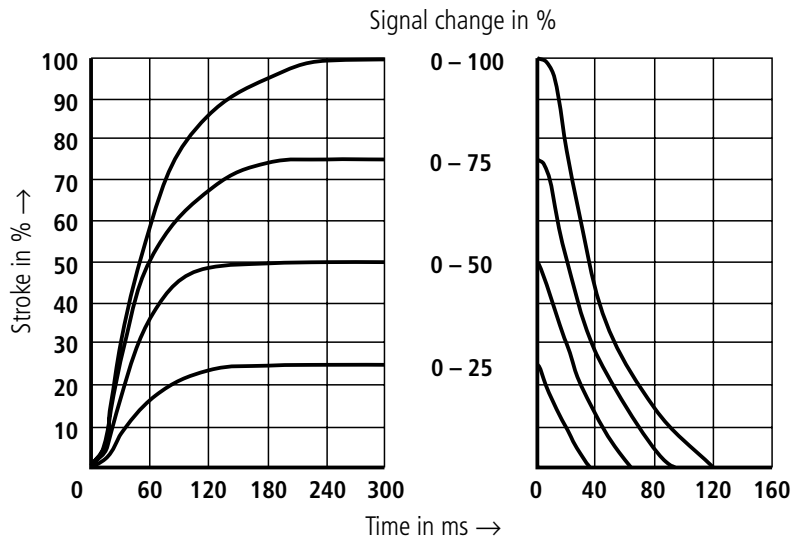

Performance limit, nominal flow 30 L/min

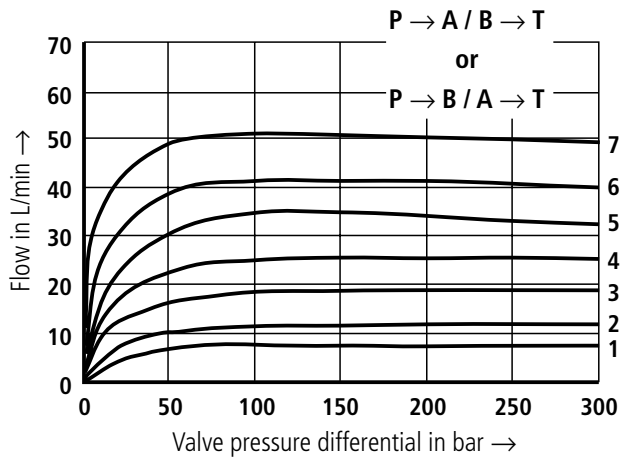

- 1 Command value = 40 %
- 2 Command value = 50 %
- 3 Command value = 60 %
- 4 Command value = 70 %
- 5 Command value = 80 %
- 6 Command value = 90 %
- 7 Command value = 100 %

Performance limit, nominal flow 60 L/min

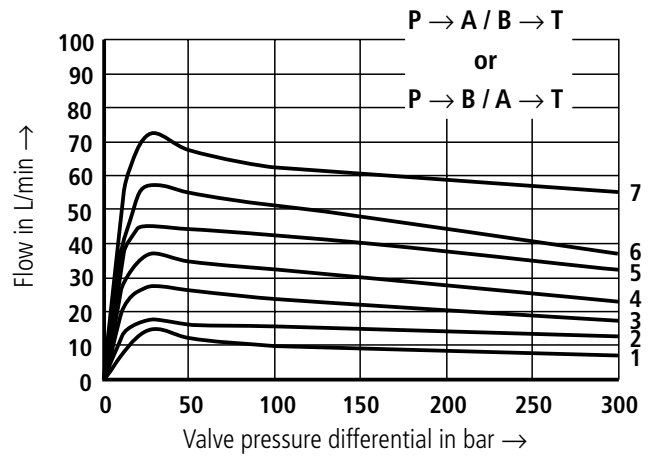

If the performance limits are exceeded then flow forces occur which lead to uncontrolled spool movements.

Unit dimensions: NS 6 (Dimensions in mm)

Type 4WRA

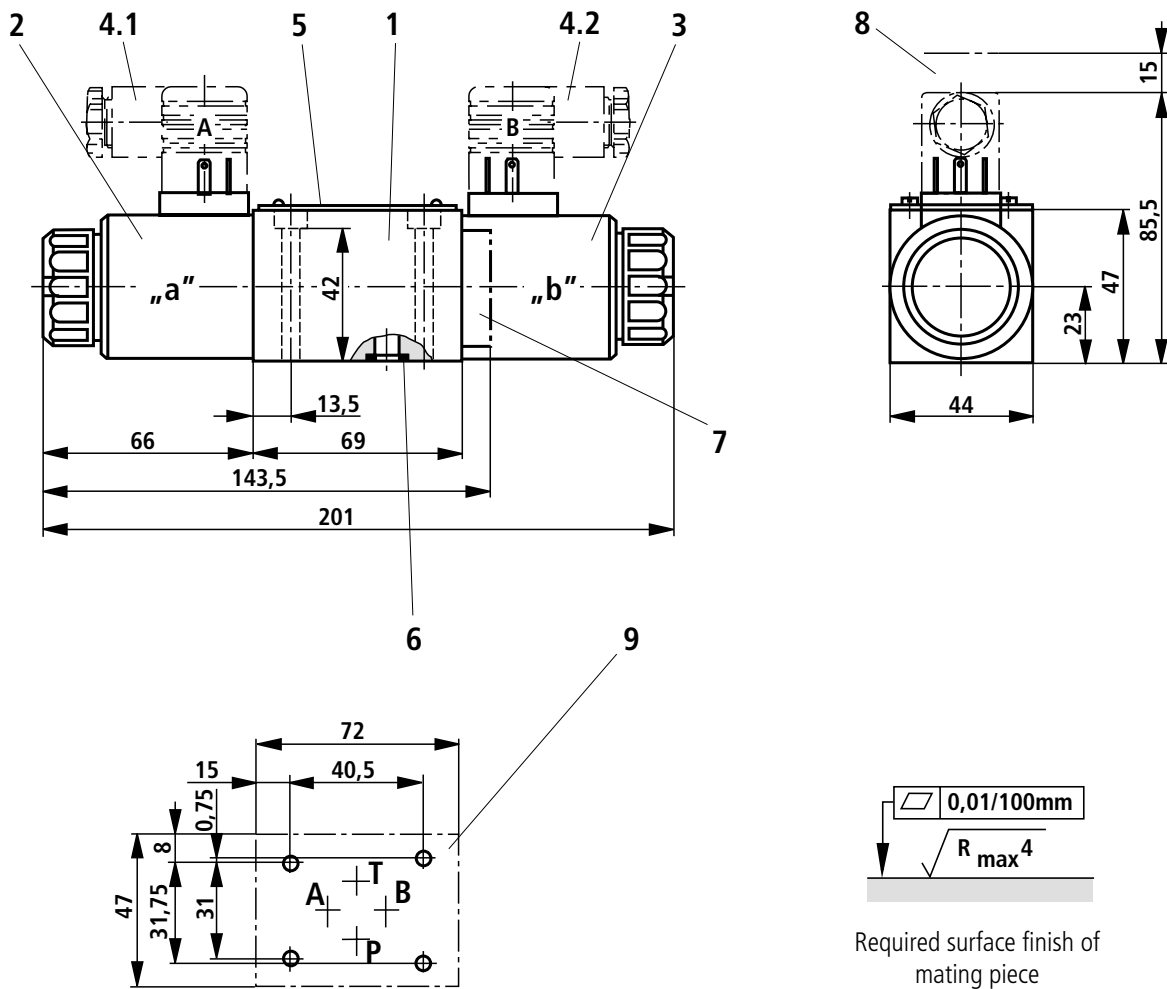

- 1 Valve housing
- 2 Proportional solenoid "a"
- 3 Proportional solenoid "b"
- 4.1 Plug-in connector "A", colour grey, separate order, see page 7
- 4.2 Plug-in connector "B", colour black, separate order, see page 7
- 5 Name plate
- 6 R-ring 9.81 x 1.5 x 1.78 (ports A, B, P, T)
- 7 Plug for valves with one solenoid (2 switched positions, versions **EA** or **WA**)
- 8 Space required to remove the plug-in connector
- 9 Machined valve mounting surface, position of the ports to DIN 24 340 form A, ISO 4401 and CETOP-RP 121 H

Subplates to catalogue sheet RE 45 052 and valve fixing screws have to be ordered separately.

Subplates: G341/01 (G1/4)
G342/01 (G3/8)
G502/01 (G1/2)

Valve fixing screws: 4 off M5 x 50 DIN 912-10.9; $M_A = 8.9$ Nm

Unit dimensions: NS 6 (Dimensions in mm)

Types 4WRAE .../...K31/...V

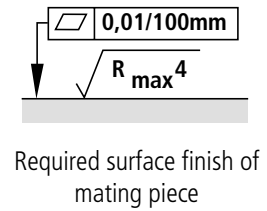
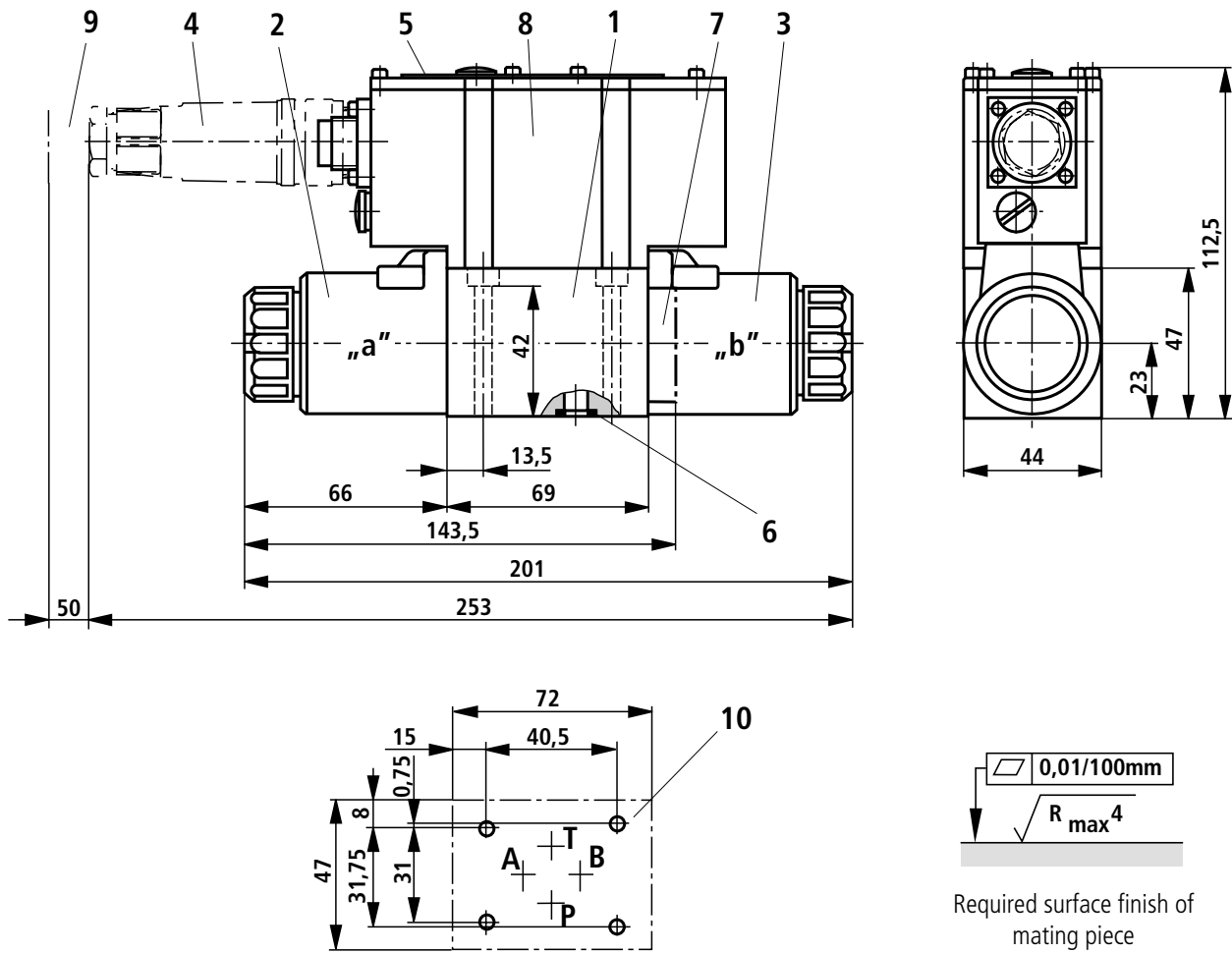

- 1 Valve housing
- 2 Proportional solenoid "a"
- 3 Proportional solenoid "b"
- 4 Plug-in connector to E DIN 43 563-BF6-3/Pg11, separate order, see page 7
- 5 Name plate
- 6 R-ring 9.81 x 1.5 x 1.78 (ports A, B, P, T)
- 7 Plug for valves with one solenoid (2 switched positions, versions **EA** or **WA**)
- 8 Integrated control electronics
- 9 Space required for the connection cable and to remove the plug-in connector
- 10 Machined valve mounting surface, position of the ports to DIN 24 340 form A, ISO 4401 and CETOP-RP 121 H

Subplates to catalogue sheet RE 45 052 and valve fixing screws have to be ordered separately.

Subplates: G341/01 (G1/4)
G342/01 (G3/8)
G502/01 (G1/2)

Valve fixing screws: 4 off M5 x 50 DIN 912-10.9 $M_A = 8.9$ Nm

Unit dimensions: NS 10 (Dimensions in mm)

Type 4WRA

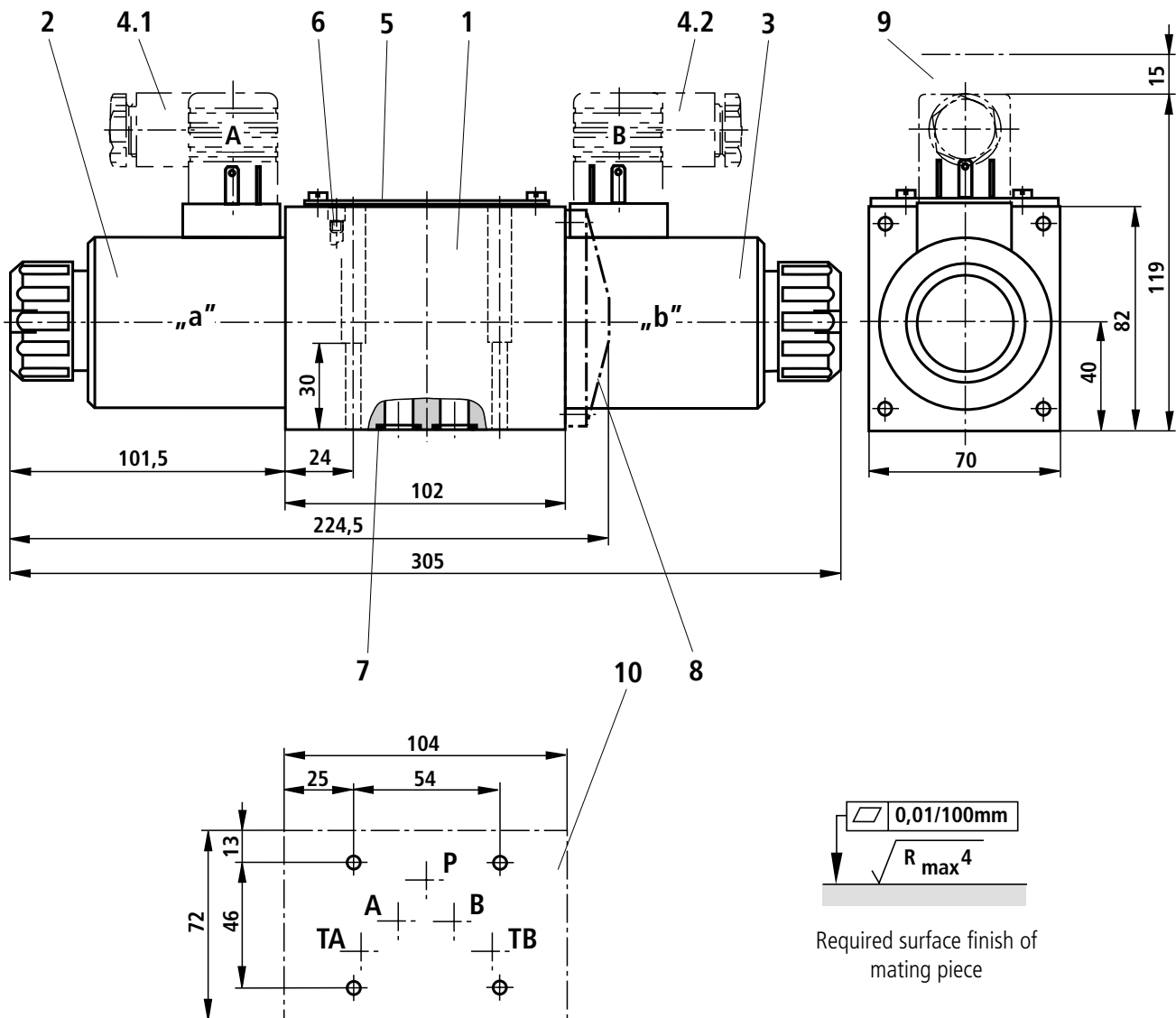

0,01/100mm
 $\sqrt{R_{max}^4}$
 Required surface finish of mating piece

- 1 Valve housing
- 2 Proportional solenoid "a"
- 3 Proportional solenoid "b"
- 4.1 Plug-in connector "A", colour grey, separate order, see page 7
- 4.2 Plug-in connector "B", colour black, separate order, see page 7
- 5 Name plate
- 6 Valve bleed screw
Note: The valves are bled before delivery.
- 7 R-ring 13.0 x 1.6 x 2.0 (ports A, B, P, T)
- 8 Plug for valves with one solenoid (2 switched positions, versions **EA** or **WA**)
- 9 Space required to remove the plug-in connector
- 10 Machined valve mounting surface, position of the ports to DIN 24 340 form A, ISO 4401 and CETOP-RP 121 H

Subplates to catalogue sheet RE 45 054 and valve fixing screws have to be ordered separately.

Subplates: G66/01 (G3/8)
 G67/01 (G1/2)
 G534/01 (G3/4)

valve fixing screws: 4 off M6 x 40 DIN 912-10.9; $M_A = 15.5$ Nm

Unit dimensions: NS 10 (Dimensions in mm)

Type 4WRAE

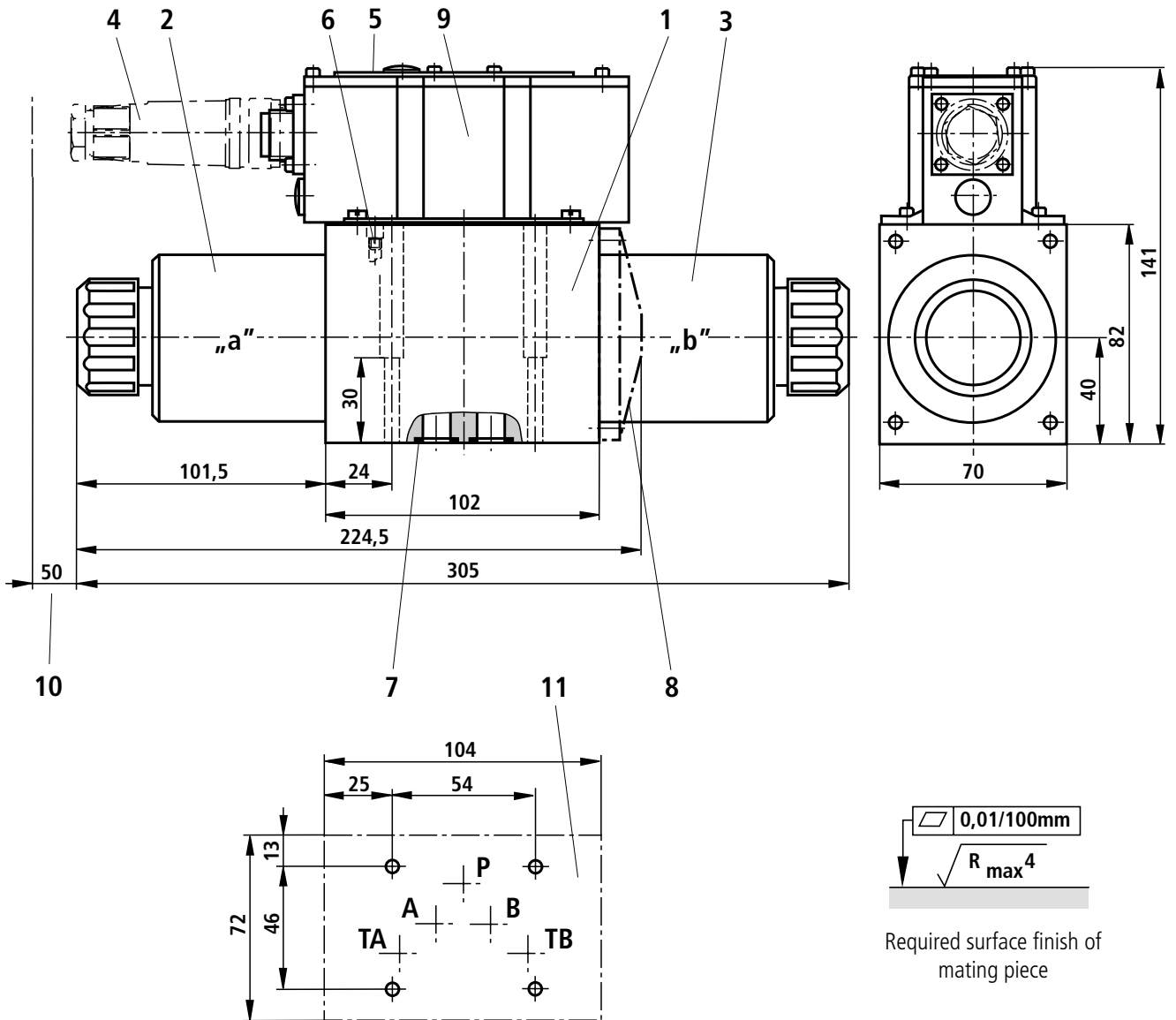

0,01/100mm
 $\sqrt{R_{max}^4}$
 Required surface finish of mating piece

- 1 Valve housing
- 2 Proportional solenoid "a"
- 3 Proportional solenoid "b"
- 4 Plug-in connector to E DIN 43 563-BF6-3/Pg11, separate order, see page 7
- 5 Name plate
- 6 Valve bleed screw
Note: The valves are bled before delivery.
- 7 R-ring 13.0 x 1.6 x 2.0 (ports A, B, P, T)
- 8 Cover for valves with one solenoid (2 switched positions, versions **EA** or **WA**)
- 9 Integrated valve electronics
- 10 Space required for the connection cable and to remove the plug-in connector
- 11 Machined valve mounting surface, position of the ports to DIN 24 340 form A, ISO 4401 and CETOP-RP 121 H

Subplates to catalogue sheet RE 45 054 and valve fixing screws have to be ordered separately.

Subplates: G66/01 (G3/8)
 G67/01 (G1/2)
 G534/01 (G3/4)

Valve fixing screws: 4 off M6 x 40 DIN 912-10.9 $M_A = 15.5$ Nm

Bosch Rexroth AG
Industrial Hydraulics

D-97813 Lohr am Main
Zum Eisengießer 1 • D-97816 Lohr am Main
Telefon 0 93 52 / 18-0
Telefax 0 93 52 / 18-23 58 • Telex 6 89 418-0
eMail documentation@boschrexroth.de
Internet www.boschrexroth.de

Bosch Rexroth Limited

Cromwell Road, St Neots,
Cams, PE19 2ES
Tel: 0 14 80/22 32 56
Fax: 0 14 80/21 90 52
E-mail: info@rexroth.co.uk

The data specified above only serve to describe the product. No statements concerning a certain condition or suitability for a certain application can be derived from our information. It must be remembered that our products are subject to a natural process of wear and ageing.